

Product data sheet

Liquid ring vacuum pump

VE series

For suction and compressor operation

Single-stage close-coupled pumps with mechanical seal and retrofit design

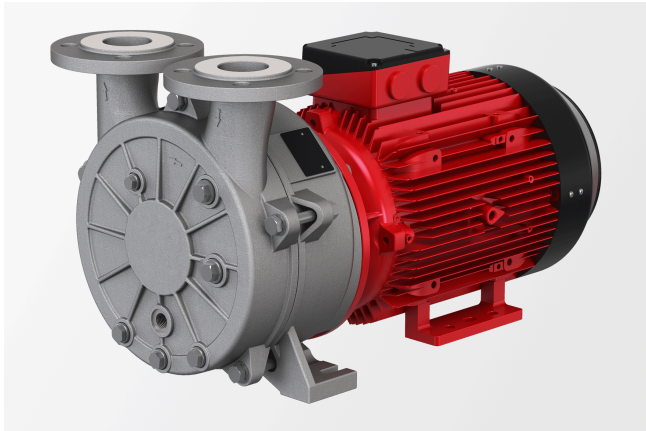

Description

- » Liquid ring vacuum pump
- » Close-coupled pump
- » Mechanical seal
- » Single-stage
- » Pump with retrofit design for existing plants with modern hydraulics
- » Eccentric at top
- » Valve flaps
- » Suitable for compressor operation
- » Specially selected materials and seals for application-specific designs
- » Oil-free vacuum generation
- » Use of condensed process medium as the operating liquid
- » Liquid carry over at a constant vacuum

Markets and applications

Chemical and pharmaceutical industry

- » Filling plants for paste media
- » Distillation
- » Filtration
- » Evaporation
- » Degasification
- » Drying of loose bulk materials
- » Solvent recovery

Plastics processing

- » Wet and dry calibration of plastic profiles
- » Extruder degasification
- » Extruder compounding
- » Polystyrene moulded parts processing
- » Manufacturing of PET (?)
- » Drying of plastic granulate
- » Decontamination in PET recycling systems

Food and beverage industry

- » Beverage filling plants
- » Vacuum cutters
- » Sous-vide cooking
- » Degasification
- » Extraction
- » Aspiration
- » Sterilisers
- » Milking robots
- » Milking machines/plants
- » Reverse osmosis systems
- » Freeze-drying

Medical technology

» Steam sterilisation systems

» Lab autoclaves

Get in touch with us!

SPECK Australia
Unit 2, 6 Glory Road
Gnangara WA 6077 Australia
Phone NZ: +61 8 6201 1286

Make a non-binding enquiry

sales@speckaustralia.com

Technical data

International system of units, alternating current 50 Hz

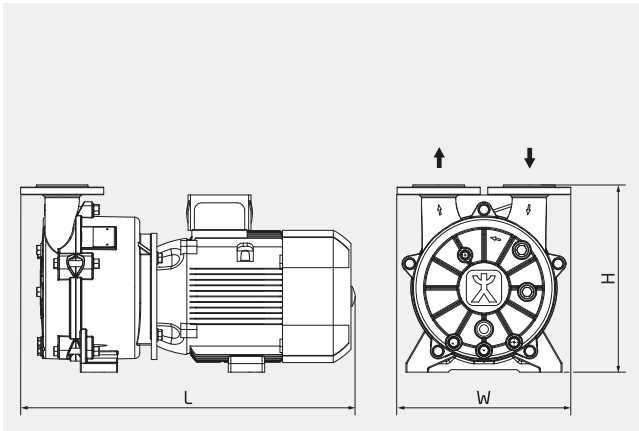

H 361-371 mm

W 345 mm

L 630-715 mm

Dimensions may vary depending on the design.

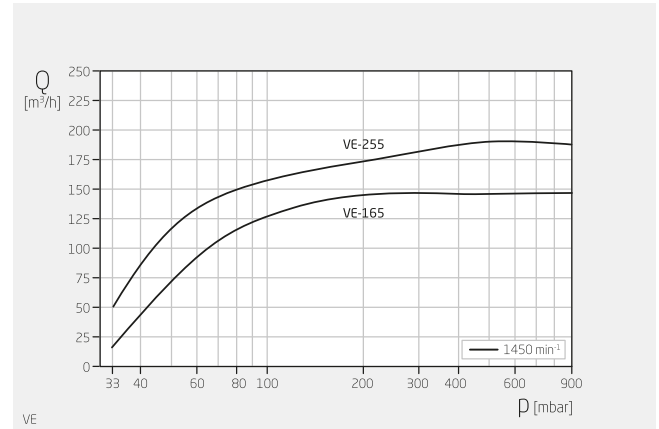

Specifications apply for dry air at 20°C at nominal speed and operating water at 15°C.

Product type	Liquid ring vacuum pump
Stages	1
Shaft sealing	Mechanical seal
Pump design	Close-coupled pump
Typical media	Dry and moist gases
Variable speed	Frequency-converter-compatible motor on request
Suction pressure ext.	33-800 mbar
Suction capacity	18.0-190.0 m³/h
Motor current type	3~
Type of motor	Asynchronous motor
Nominal motor power	4.0 - 5.5 kW
Nominal motor speed	1450 rpm
Suction-side connection design	Flange in acc. with DIN EN 1092 and ANSI B 16.5
Suction-side connection size	DN 50
Pressure-side connection design	Flange in acc. with DIN EN 1092 and ANSI B 16.5
Pressure-side connection size	DN 50
Material designs	Grey cast iron
Explosion protection	None II 3G, II 3D II 2G, II 2D II 2/2G

Technical data

International system of units, alternating current 60 Hz

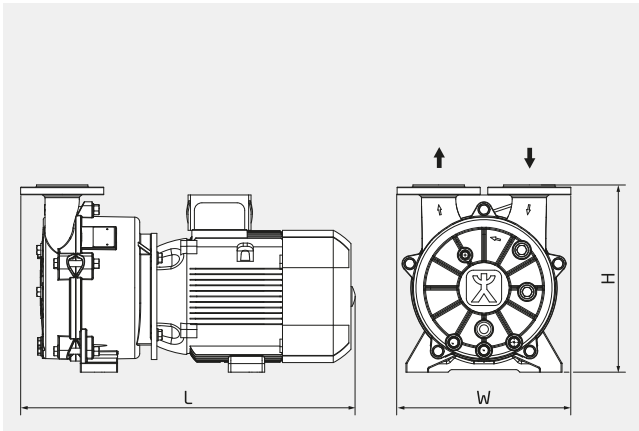

H 361-371 mm

W 345 mm

L 630-715 mm

Dimensions may vary depending on the design.

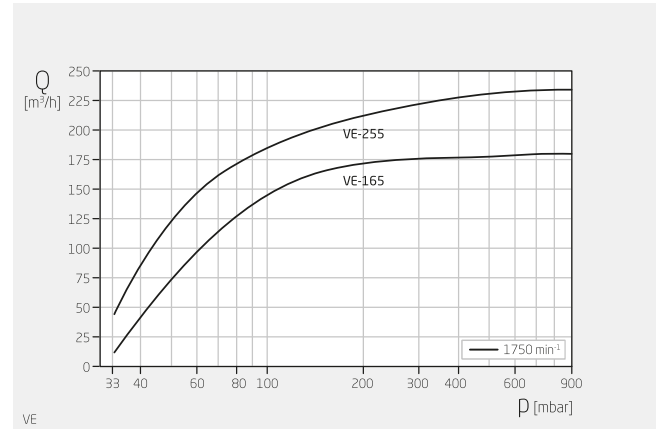

Specifications apply for dry air at 20°C at nominal speed and operating water at 15°C.

Product type	Liquid ring vacuum pump
Stages	1
Shaft sealing	Mechanical seal
Pump design	Close-coupled pump
Typical media	Dry and moist gases
Variable speed	Frequency-converter-compatible motor on request
Suction pressure ext.	33-800 mbar
Suction capacity	16.0-235.0 m³/h
Motor current type	3~
Type of motor	Asynchronous motor
Nominal motor power	6.2 - 8.2 kW
Nominal motor speed	1750 rpm
Suction-side connection design	Flange in acc. with DIN EN 1092 and ANSI B 16.5
Suction-side connection size	DN 50
Pressure-side connection design	Flange in acc. with DIN EN 1092 and ANSI B 16.5
Pressure-side connection size	DN 50
Material designs	Grey cast iron
Explosion protection	None II 3G, II 3D II 2G, II 2D II 2/2G

Technical data

Anglo-American system of measurement, alternating current 60 Hz

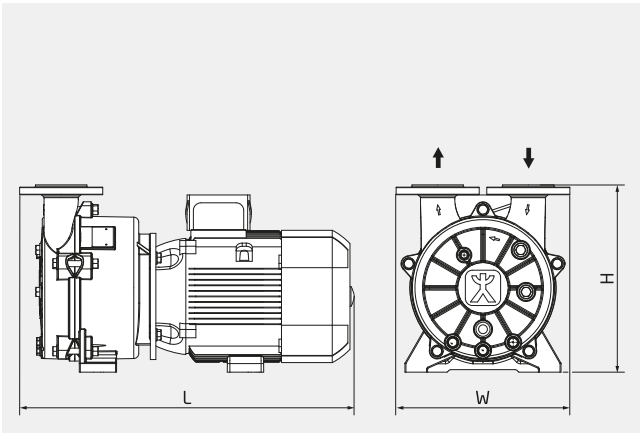

H 14,21-14,61 inch

W 13,58 inch

L 24,80-28,15 inch

Dimensions may vary depending on the design.

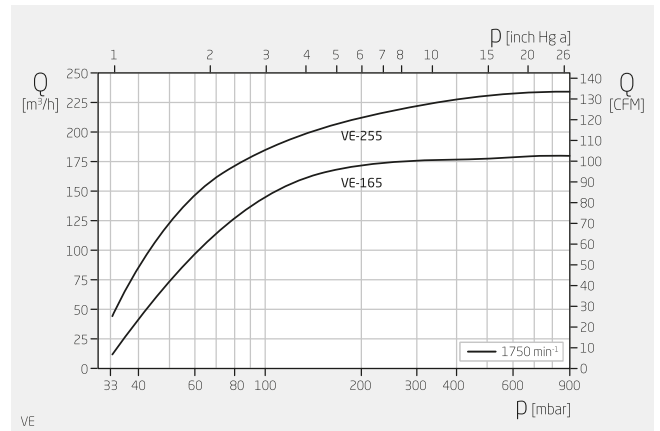

Specifications apply for dry air at 68 °F at nominal speed and operating water at 59 °F.

Product type	Liquid ring vacuum pump
Stages	1
Shaft sealing	Mechanical seal
Pump design	Close-coupled pump
Typical media	Dry and moist gases
Variable speed	Frequency-converter-compatible motor on request
Suction pressure ext.	1.0-23.6 inHg
Suction capacity	9.4-138.3 CFM
Motor current type	3~
Type of motor	Asynchronous motor
Nominal motor power	8.3-11.0 HP
Nominal motor speed	1750 rpm
Suction-side connection design	Flange in acc. with DIN EN 1092 and ANSI B 16.5
Suction-side connection size	DN 50
Pressure-side connection design	Flange in acc. with DIN EN 1092 and ANSI B 16.5
Pressure-side connection size	DN 50
Material designs	Grey cast iron
Explosion protection	None II 3G, II 3D II 2G, II 2D II 2/2G